



TOREX®



1

TECHNICAL CATALOGUE

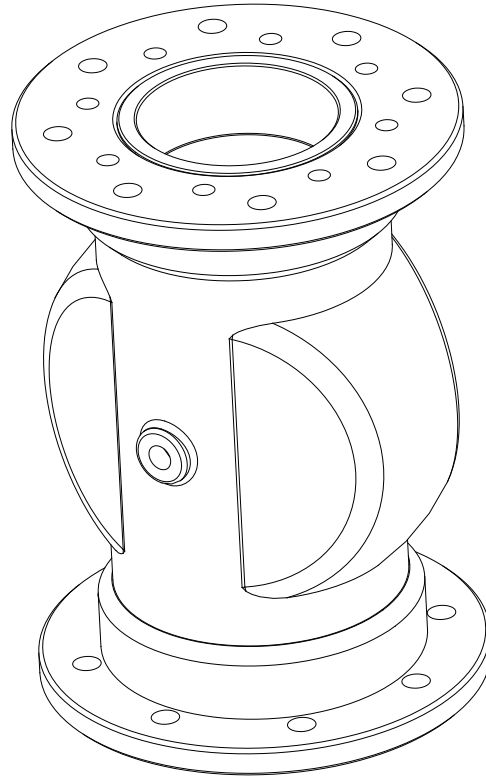

VM

- **PINCH VALVES**
TECHNICAL CATALOGUE
- **QUETSCHVENTILE**
TECHNISCHER KATALOG
- **VANNES A MANCHON**
CATALOGUE TECHNIQUE
- **VALVOLE A MANICOTTO**
CATALOGO TECNICO

All rights reserved © WAMGROUP S.p.A.

CATALOGUE No. TOR.132.--.T.4L			
ISSUE A7	CIRCULATION 100	LATEST UPDATE 03.12	



All the products described in this catalogue are manufactured according to **TOREX S.p.A. Quality System procedures**. The Company's Quality System, certified according to **ISO 9001-2008** guarantees that the entire production process, from the customer's order to the after sales service, can fulfil the product quality standard.

*Alle in diesem Katalog beschriebenen Produkte werden gemäß dem **Qualitätssystem der TOREX S.p.A. hergestellt**. Das gemäß der internationalen Norm **ISO 9001-2008** zertifizierte Qualitätssystem der Firma gewährleistet, dass der gesamte Produktionsprozess von der Auftragsbearbeitung bis zum technischen Kundendienst nach Lieferung den Qualitätsstandard des Produkts erfüllt.*

Tous les produits décrits dans ce catalogue sont fabriqués selon les **procédures du Système de Qualité de TOREX S.p.A.**, certifié selon les normes **ISO 9001-2008**. Cela garantit que le processus de production, à partir de la gestion de la commande au service technique après-vente, est effectué de manière contrôlée garantissant la norme de qualité du produit.

*Tutti i prodotti descritti nel catalogo sono stati realizzati secondo le **procedure del Sistema Qualità di TOREX S.p.A.** Il Sistema Qualità aziendale, certificato in conformità alle normative internazionali **ISO 9001-2008** garantisce che l'intero processo produttivo, dalla formulazione dell'ordine fino all'assistenza tecnica dopo la consegna, si svolge secondo modalità controllate che garantiscono lo standard qualitativo del prodotto.*

**This publication cancels and replaces any previous edition and revision.
We reserve the right to implement modifications without notice.
This catalogue cannot be reproduced, even partially, without prior consent.**

***Diese Veröffentlichung storniert und ersetzt alle früheren Ausgaben und überarbeiteten Fassungen.
Wir behalten uns das Recht vor, Änderungen ohne vorherige Information durchzuführen.
Dieser Katalog darf ohne vorherige Genehmigung weder ganz noch teilweise vervielfältigt werden.***

**Cette publication annule et remplace toute édition et révision antérieure.
Nous nous réservons le droit de mettre en place des modifications sans préavis.
Ce catalogue ne peut être reproduit, même partiellement, sans notre consentement préalable.**

***Questa pubblicazione annulla e sostituisce le edizioni e revisioni precedenti.
Ci riserviamo la facoltà di apportare modifiche senza preavviso.
Il presente catalogo non può essere riprodotto, nemmeno parzialmente, senza previo consenso.***



Considerations on the Application of Directive ATEX to the pinch valve series "VM"

As a result of the assessment work about the ignition hazards and all other verification activities to the Essential Health And Safety Requirements conformity expressed by the Directive 94/9/CE (based the comparison with the harmonized standards) TOREX has found that the only source of ignition hazards potentially present in the inner zone (or process zone) of the pinch valve is the electrostatics charging due to the passage of the dust through the contact parts of the sleeve.

Considering the Directive 94/9/CE emitted by the European Community (ATEX Guidelines - second edition - May 2007) that defines:

"If the only source of electrostatic charging comes from the process, such items are not considered to have their own source of ignition, and they are not in scope of directive 94/9/EC. In these cases they should not be Ex or CE marked according to directive 94/9/EC"

The equipment cannot be considered in the field of application of the Directive 94/9/CE, having no other sources of risk outside of those electrostatics charging generated by the flow of the dust material against the contact surfaces: anyway, the Pinch Valve will still remain suitable to work with a process zone classified as ZONE 20 and external zones classified as ZONE 22.

The only additional measure to be adopted for this application is: the connection of the valve to the plant's earth circuit. (See next page)



Betrachtungen zur Anwendung der ATEX-Richtlinie beim Quetschventil „VM“

Im Anschluss an die Beurteilung der Zündgefahr und aller anderen Tätigkeiten zur Konformitätsprüfung an die R.E.S.S, die in der Richtlinie 94/9/EG aufgeführt sind (basierend auf dem Vergleich mit den harmonisierten Normen), hat TOREX S.p.A eine einzige potentielle Zündquelle festgestellt, die im Innenbereich (oder im Prozessbereich des Ventils vorhanden ist, und zwar die elektrostatische Ladung, die der Durchlauf des Schüttguts verursachen kann.

Unter Berücksichtigung dessen, was die Anleitung zur Richtlinie 94/9/EG vorsieht, die von der Europäischen Union ausgestellt wurde (Atex Guidelines – 2nd edition – May 2007), die festlegt:

"If the only source of electrostatic charging comes from the process, such items are not considered to have their own source of ignition, and they are not in scope of directive 94/9/EC. In these cases they should not be Ex or CE marked according to directive 94/9/EC"

Das Gerät kann nicht im Anwendungsrahmen der Richtlinie 94/9/EG betrachtet werden, da es keine weiteren Zündquellen außerhalb der elektrostatischen hat, die durch das Laden der Oberflächen infolge des Durchlaufs des Schüttguts zustande kommt: Es bleibt für das Ventil die Möglichkeit bestehen, bei Innenbereichen mit Einstufung als ZONE 20 und bei Außenbereichen mit Einstufung als ZONE 22 verwendet zu werden..

Die einzige zusätzliche Maßnahme, die für diesen Anwendungstyp anzuwenden ist, ist: der Anschluss des Ventils an den Erdungskreis der Anlage. (siehe nächste Seite)



Remarques sur l'Application de la Directive ATEX à la vanne à Manchon série « VM ».

Après évaluation du risque d'inflammation et de toutes les autres activités de contrôle de conformité aux Exigences Essentielles de Sécurité et de Santé exprimées par la Directive 94/9/CE (fondées sur la confrontation avec les standards harmonisés), TOREX S.p.A a relevé que l'unique source d'inflammation potentiellement présente dans la zone interne (ou de processus) de la vanne est la charge électrostatique pouvant être engendrée par le passage du produit pulvérulent.

Compte tenu de ce qui est prévu par le Guide à la Directive 94/9/CE émis par la Communauté Européenne (Atex Guidelines – deuxième édition – Mai 2007) qui définit :

"If the only source of electrostatic charging comes from the process, such items are not considered to have their own source of ignition, and they are not in scope of directive 94/9/EC. In these cases they should not be Ex or CE marked according to directive 94/9/EC."

L'équipement ne peut pas être considéré dans le cadre d'application de la Directive 94/9/CE, n'ayant pas d'autres sources d'inflammation en dehors de celles électrostatiques que le chargement des surfaces engendre par l'écoulement de produit. Il demeure toutefois possible que la vanne puisse être employée avec des zones internes classées ZONE 20 et zones extérieures classées ZONE 22.

La seule mesure supplémentaire à adopter pour ce type d'application est: le raccordement de la vanne au circuit de mise à la terre de l'installation. (Voir page suivante).



Considerazioni sulla Applicazione della Direttiva ATEX alla valvola a Manicotto serie "VM"

A seguito della valutazione del pericolo di accensione e di tutte le altre attività di verifica di conformità ai R.E.S.S espressi dalla Direttiva 94/9/CE (basate sul confronto con gli standard armonizzati) la TOREX S.p.A ha rilevato che l'unica sorgente d'innescio potenzialmente presente nella zona interna (o di processo) della valvola è la carica elettrostatica che il passaggio del materiale polverulento può causare.

Considerando quanto previsto dalla Guida alla Direttiva 94/9/CE emessa dalla Comunità Europea (Atex Guidelines – second edition – May 2007) che definisce:

"If the only source of electrostatic charging comes from the process, such items are not considered to have their own source of ignition, and they are not in scope of directive 94/9/EC. In these cases they should not be Ex or CE marked according to directive 94/9/EC"

L'attrezzatura non può essere considerata nel campo di applicazione della Direttiva 94/9/CE, non avendo altre sorgenti d'innescio al di fuori di quelle elettrostatiche generate dal caricamento delle superfici ad opera del flusso del materiale: resta comunque la possibilità per la valvola di essere impiegata con zone interne classificate come ZONA 20 e zone esterne classificate come ZONA 22.

L'unica due misura aggiuntiva da adottare per questo tipo di applicazione è: il collegamento della valvola al circuito di terra dell'impianto. (Vedere pagina seguente)



Before carrying out any operation, make sure the machine is in safety condition!

The installation technician must connect the pinch valve to the plant's earth circuit using one of the fixing bolts and check to ensure equipotentiality of all its parts before starting up the machine. In case of valves with threaded bushings, the valve must be connected by means of an earth cable as show in the Figure below. The minimum cross-section of the cable used must be 10 mm².



Vor Eingriffen jeder Art am Gerät überprüfen, ob dieses in einen sicheren Zustand versetzt wurde!

Der Monteur muss das Quetschventil mittels einer der Befestigungsschrauben an den Erdungskreis der Anlage anschließen und den tatsächlichen Potentialausgleich aller ihrer Teile prüfen, bevor er das Gerät in Betrieb nimmt. Bei Ventilen mit Gewindebuchsen ist es erforderlich, das Ventil mit einem Erdungskabel anzuschließen, so wie in der folgenden Abbildung dargestellt. Der Mindestquerschnitt des zu verwendenden Kabels beträgt 10 mm².



Avant d'effectuer une quelconque intervention sur la machine s'assurer que celle-ci a été placée en condition de sécurité!

L'installateur devra brancher la vanne à manchon au circuit de mise à la terre de l'équipement à travers un des boulons de fixation et vérifier l'équipotentialité effective de toutes ses parties avant de mettre la machine en marche. Dans le cas de vannes à bagues filettées il est nécessaire de raccorder la vanne avec un câble de mise à la terre comme illustré dans la figure ci-dessous. Le câble utilisé devra avoir une section minimum de 10 mm².



Prima di effettuare un qualsiasi intervento sulla macchina assicurarsi che questa sia messa in sicurezza!

L'installatore dovrà collegare la valvola a manicotto al circuito di terra dell'impianto tramite uno dei bulloni di fissaggio e verificarne l'effettiva equipotenzialità di tutte le sue parti prima di avviare la macchina. Nel caso di valvole con boccole filettate è necessario collegare la valvola con un cavo di messa a terra nel modo illustrato nella figura sottostante. La sezione minima del cavo da utilizzare è di 10 mm².

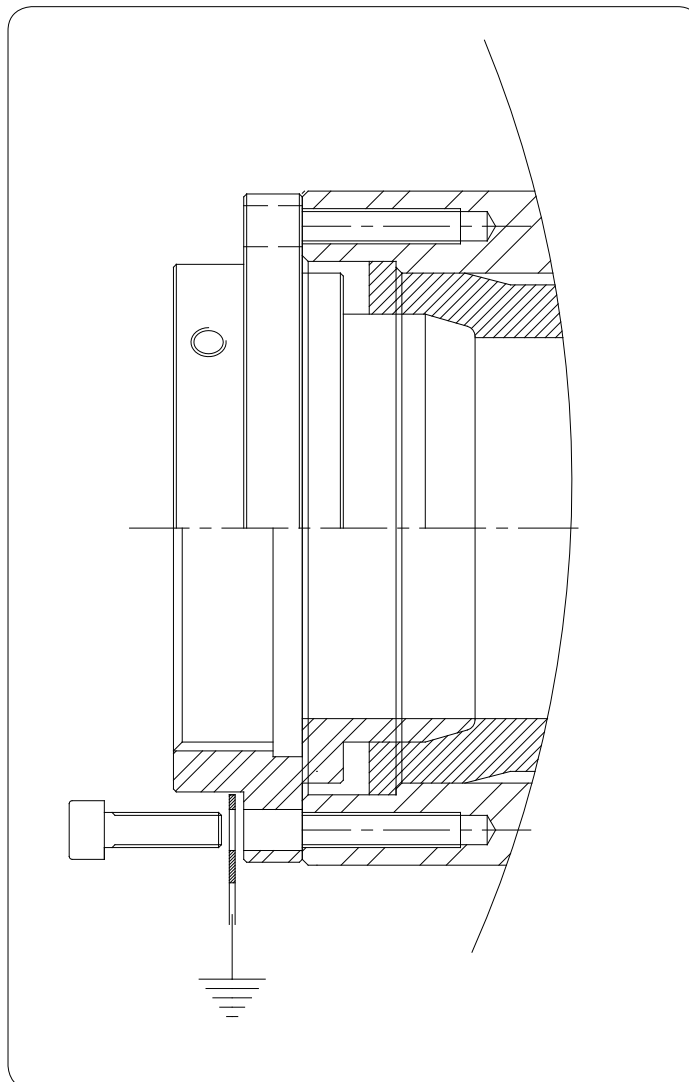

1	TECHNICAL CATALOGUE	TECHNISCHER KATALOG	
	EARTH CONNECTIONS.....	ANSCHLÜSSE AN DAS ERDUGSNETZ.....	T. 00
	INTRODUCTION.....	EINFÜHRUNG.....	.01
	COMPONENTS - TECHNICAL DATA.....	BESTANDTEILE - TECHNISCHE DATEN.....	.02
	DIMENSIONS.....	ABMESSUNGEN.....	.03
	ORDER CODES.....	BESTELLCODES.....	.04
	ACCESSORIES - CONTROL PANEL VMX01.....	ZUBEHÖR - STEUREUNG VMX01.....	.05 → .06
	ACCESSORIES - TECHNICAL DATA.....	ZUBEHÖR - TECHNISCHE DATEN.....	.07 → .08
	INQUIRY FORM.....	ANFRAGEFORMULAR.....	.09
1	CATALOGUE TECHNIQUE	CATALOGO TECNICO	
	RACCORDEMENTS A LA MISE A LA TERRE.....	COLLEGAMENTI ALLA RETE A TERRA.....	T. 00
	INTRODUCTION.....	INTRODUZIONE.....	.01
	COMPOSANTS- CARACTERISTIQUES TECHNIQUES.....	COMPONENTI - DATI TECNICI.....	.02
	DIMENSIONS.....	DIMENSIONI.....	.03
	CODES DE SELECTION.....	CODICI DI SCELTA.....	.04
	ACCESSOIRES - TABLEAU DE COMMANDE VMX01.....	ACCESSORI - QUADRO DI COMANDO VMX01.....	.05 → .06
	ACCESSOIRES - DONNEES TECHNIQUES.....	ACCESSORI - DATI TECNICI.....	.07 → .08
	FORMULAIRE DE DEMANDE.....	MODULO DI RICHIESTA.....	.09

<p>TYPE Pinch valve</p>	<p>TYP Quetschventil</p>	<p>TYPE Vanne à manchon</p>	<p>TIPO Valvola a manicotto</p>
<p>DESCRIPTION Material flow intercepting valve.</p>	<p>BESCHREIBUNG Ventil zur Unterbrechung des Materialflusses.</p>	<p>DESCRIPTION Vanne d'interception</p>	<p>DESCRIZIONE Valvola intercettazione materiali.</p>
<p>USE VM pinch valves are designed to control the delivery of powder or granulated products during pneumatic transport, particularly during the pneumatic loading of silos from tankers.</p>	<p>BETRIEBSFUNKTION VM Quetschventile eignen sich zum Unterbrechen des Materialflusses von Schüttgütern während der pneumatischen Förderung, insbesondere zur pneumatischen Beschickung von Silos durch Silofahrzeuge.</p>	<p>UTILISATION Les vannes à manchon modèle VM sont indiquées pour intercepter des produits en poudre ou granulaires pendant le transport pneumatique, en particulier pendant le remplissage pneumatique des silos au moyen d'un camion citerne.</p>	<p>FUNZIONE D'USO Le valvole a manicotto modello VM sono indicate per l'intercettazione di prodotti in polvere o granulari durante il trasporto pneumatico, in particolare durante il carico pneumatico di silos mediante autocisterna.</p>
<p>IMPROPER USE VM pinch valves are NOT designed to work in dangerous conditions or with dangerous materials. If the equipment has to be operated in these conditions the Manufacturer must be informed.</p>	<p>KONTRAINDIKATIONEN Quetschventile in der VM Standardversion sind NICHT zum Einsatz unter gefährlichen Bedingungen oder zum Handling gefährlicher Medien geeignet. Wenn das Gerät für Einsätze dieser Art bestimmt ist, ist die Rücksprache mit dem Hersteller erforderlich.</p>	<p>CONTRE-INDICATIONS Les vannes à manchon standard de la classe VM N'ONT PAS été projetées pour travailler dans ces conditions ou avec des matières dangereuses. Par conséquent, quand l'équipement doit remplir cette condition le constructeur doit obligatoirement en être informé.</p>	<p>CONTROINDICAZIONI Le valvole a manicotto standard della classe VM NON sono state progettate per operare in condizioni o con materiali pericolosi; pertanto quando la macchina deve assolvere a queste esigenze è d'obbligo informare il costruttore.</p>
<p>Dangerous materials: - explosives - toxic - inflammable - harmful and similar.</p>	<p>Als gefährlich sind folgende Medien zu betrachten: - explosive Produkte - giftige Materialien - feuergefährliche Materialien - schädliche Medien und ähnliche.</p>	<p>Sont considérées matériaux dangereux: - toxiques - inflammables - nocifs et semblables</p>	<p>Si ritengono materiali pericolosi: - materiali esplosivi - tossici - infiammabili, - nocivi e/o simili.</p>
<p>Dangerous applications: - conveying or filling the materials listed above into bins or silos.</p>	<p>Als gefährlich werden folgende Anwendungen betrachtet: - Austragung aus Silos oder Ladezellen, die die oben genannten Materialien enthalten.</p>	<p>Sont considérées applications dangereuses: - extraction de silos ou chambres contenant des matières dangereuses.</p>	<p>Si ritengono applicazioni pericolose: - estrazione da silo o celle contenenti i suddetti materiali.</p>

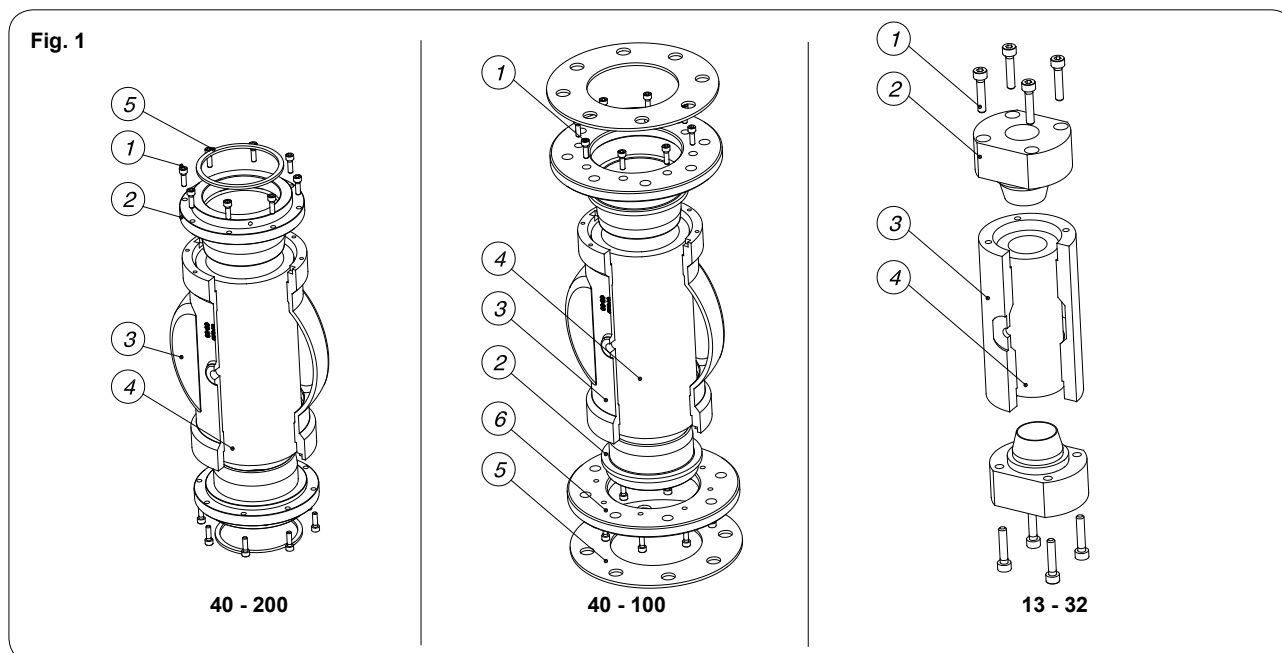
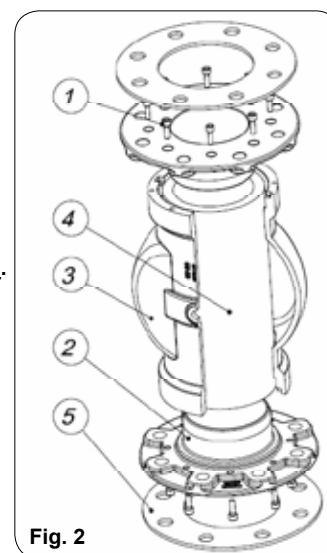

Fig. 1 Sizes - Baugrößen von - Tailles de - Taglie da 40-200 ; 40-100 ; 13-32

Item Pos.	Description - Beschreibung - Désignation - Descrizione
1	Bolts - Schrauben - Vis - Viti
2	Bush - Buchse - Embout - Boccola
3	Body - Gehäuse - Corps - Corpo
4	Sleeve - Manschette - Manchon - Manicotto
5	Seal - Dichtung - Joint - Guarnizione
6	Flange - Flansch - Bride - Flangia

Fig. 2 Configurations Konfigurationen Configurations Configurazioni VM080AA_ e VM100AA_

Pos.	Descrizione
1	Bolts - Schrauben - Vis - Viti
2	Bush+Flange - Buchse+Flansch - Embout+Bride - Boccola+Flangia
3	Body - Gehäuse - Corps - Corpo
4	Sleeve - Manschette - Manchon - Manicotto
5	Seal - Dichtung - Joint - Guarnizione

BUSH

- Aluminium
- Hardened
- AISI 304 Stainless steel
- AISI 316 Stainless steel

THREADED BUSH

- Aluminium
- Plastic (for VM 13, 20, 25, 32 only)
- Hardened
- AISI 304 Stainless steel
- AISI 316 Stainless steel

BODY

- Die-cast aluminium

FLANGE

- Aluminium

FLANGE U.S.A. STANDARDS

- Aluminium

SLEEVE

- Natural rubber
- Food-grade NBR

GASKET

- Black rubber

BUCHSE

- Aluminium
- Gehärtet
- Edelstahl 1.4301
- Edelstahl 1.4401

GEWINDEBUCHSE

- Aluminium
- Kunststoff (nur für VM 13, 20, 25, 32)
- Gehärtet
- Edelstahl 1.4301
- Edelstahl 1.4401

GEHÄUSE

- Aluminiumdruckguss

FLANSCH

- Aluminium

FLANSCH NACH US-NORM

- Aluminium

MANSCHETTE

- Naturgummi
- NBR lebensmittelecht

DICHTUNG

- Schwarzes Gummi

BAGUE

- Aluminium
- Trempés
- Acier Inox AISI 304
- Acier Inox AISI 316

BAGUE FILETÉE

- Aluminium
- Plastique (seulement pour VM 13, 20, 25, 32)
- Trempés
- Acier Inox AISI 304
- Acier Inox AISI 316

CORPS

- Moulage sous pression d'Aluminium

BRIDE

- Aluminium

BRIDE NORMES U.S.A.

- Aluminium

MANCHON

- Caoutchouc Naturel
- NBR de qualité alimentaire

JOINT

- Caoutchouc Noir

BOCCOLA

- Alluminio
- Indurite
- Acciaio Inox AISI 304
- Acciaio Inox AISI 316

BOCCOLA FILETTATA

- Alluminio
- Plastica (solo per VM 13, 20, 25, 32)
- Indurite
- Acciaio Inox AISI 304
- Acciaio Inox AISI 316

CORPO

- Pressofusione di Alluminio

FLANGIA

- Alluminio

FLANGIA NORME U.S.A.

- Alluminio

MANICOTTO

- Gomma Naturale
- NBR alimentare

GUARNIZIONE

- Gomma Nera

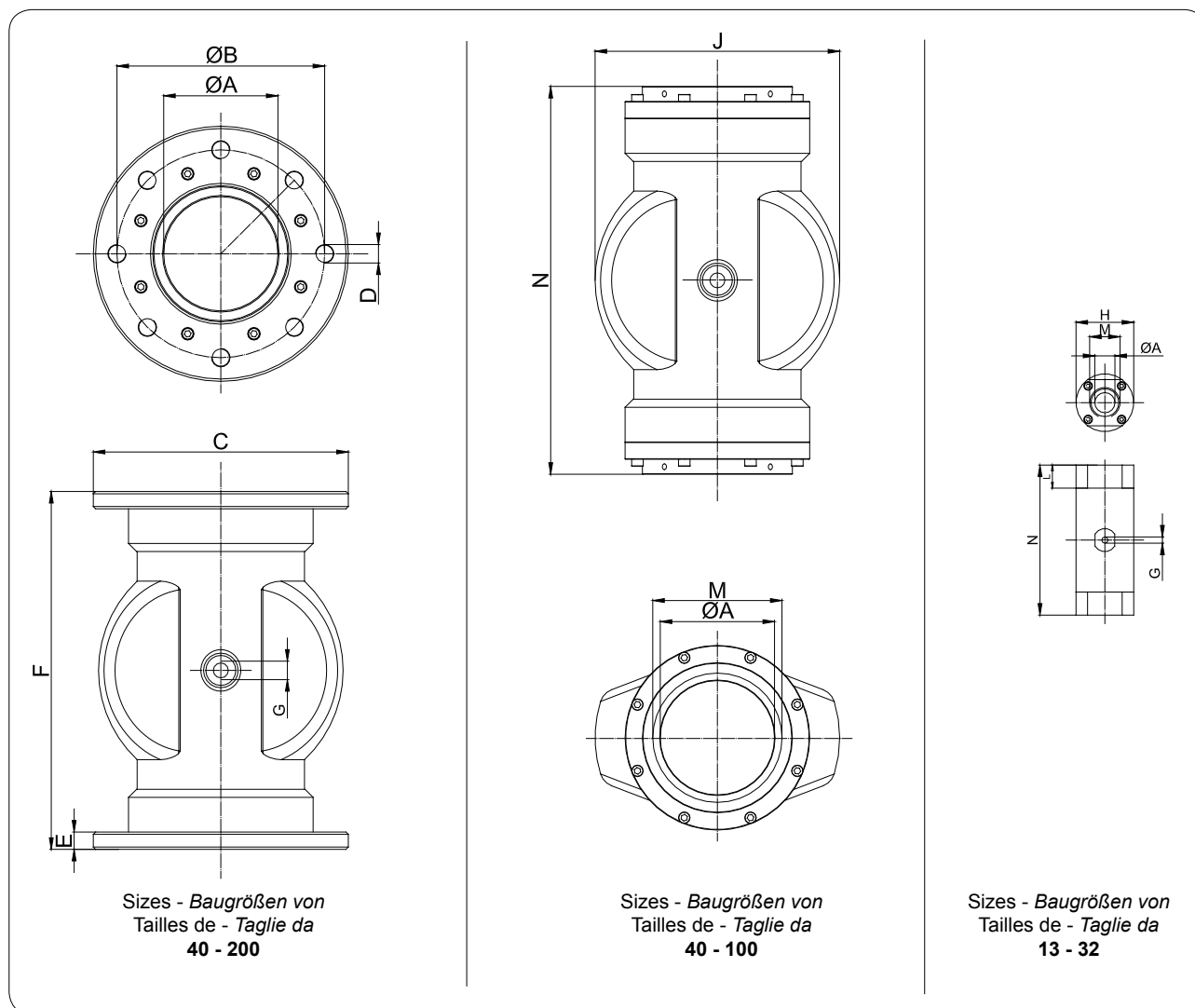

Type	A	B	C	D		E	F	G	H	J	L	M	N	Weights - Gewichte Poids - Pesi kg
				\varnothing	n°									
VM013	13							1/8"	42		18	1/2"	120	0.40
VM020	20							1/8"	50		20	3/4"	130	0.50
VM025	25							1/8"	56		22	1"	130	0.70
VM032	32							1/8"	70		25	1 + 1/4"	165	1.10
VM040	40	110	150	M 16	4	12	178	1/8"		99		1 + 1/2"	202	2.20
VM050	50	125	165	M 16	4	15	190	1/8"		114		2"	214	3.40
VM065	65	145	185	M 16	4	15	225	1/4"		138		2 + 1/2"	230	4.00
VM080	80	160	200	M 16	4	15	270	1/4"		180		3"	294	5.40
VM0100	100	180	220	M 16	8	15	310	1/4"		214		4"	334	7.60
VM0125	125	210	250	M 16	8	15	350	1/4"		250				10.20
VM0150	150	240	285	M 16	8	18	396	1/4"		285				15.60
VM0200	200	295	340	M 16	8	25	460	1/4"		374				22.80

Valve Ventil Vanne Valvola	∅	Inlet Einlauf Entrée Ingresso	Outlet Auslauf Sortie Uscita	Sleeve Manschette Manchon Manicotto
-------------------------------------	---	--	---------------------------------------	--

0	Natural rubber - <i>Naturkautschuk</i> Caoutchouc naturel - <i>Gomma naturale</i>
1	NBR food-grade - <i>NBR nahrungsmitteltauglich</i> NBR alimentaire - <i>NBR alimentare</i>

A	Flange and bush in aluminium - <i>Flansche und Buchsen aus Aluminium</i> Brides et embouts en aluminium - <i>Flange e boccole in alluminio</i>
B	Aluminium flange and hardened bush - <i>Flansche aus Aluminium, Buchsen gehärtet</i> Brides en aluminium et embouts durcis - <i>Flangia in alluminio e boccole indurite</i>
C	Aluminium flange and Stainless steel (AISI 304) bush - <i>Flansche Alu, Buchsen 1.4301</i> Brides en aluminium et embouts en Inox 304 - <i>Flangia in alluminio e boccole in AISI304</i>
D	Aluminium flange and Stainless steel (AISI 316) bush - <i>Flansche Alu, Buchsen 1.4401</i> Brides en aluminium et embouts en Inox 316 - <i>Flangia in alluminio e boccole in AISI316</i>
E	Flange and bush in aluminium (USA norm) - <i>Flansche gem. US-Norm, Buchsen aus Alu</i> Brides à normes USA et embouts en aluminium - <i>Flange (Norme USA)e boccole in alluminio</i>
F	Aluminium threaded bush - <i>Gewindebuchse aus Aluminium</i> Embout fileté en aluminium - <i>Boccola filettata in alluminio</i>
G	Plastic threaded bush - <i>Gewindebuchse aus Kunststoff</i> Embout fileté en plastique - <i>Boccola filettata in plastica</i>
H	Stainless steel (AISI 304) threaded bush - <i>Gewindebuchse aus Edelstahl 1.4301</i> Embout fileté en acier inox 304 - <i>Boccola filettata in AISI304</i>
I	Stainless steel (AISI 316) threaded bush - <i>Gewindebuchse aus Edelstahl 1.4401</i> Embout fileté en acier inox 316 - <i>Boccola filettata in AISI 316</i>
L	Hardened threaded bush - <i>Gewindebuchse gehärtet</i> Embout fileté durci - <i>Boccole filettate indurite</i>
M	Stainless steel (AISI 304) threaded bush (Thyssen) - <i>Gewindebuchse aus 1.4301 (Thyssen)</i> Embout fileté en inox 304 (Thyssen) - <i>Boccola filettata in AISI 304 (Thyssen)</i>

A	Flange and bush in aluminium - <i>Flansche und Buchsen aus Aluminium</i> Brides et embouts en aluminium - <i>Flange e boccole in alluminio</i>
B	Aluminium flange and hardened bush - <i>Flansche Alu und Buchsen gehärtet</i> Brides en aluminium et embouts durcis - <i>Flangia in alluminio e boccole indurite</i>
C	Aluminium flange and Stainless steel (AISI304) bush - <i>Flansche aus Alu, Buchsen 1.4301</i> Brides en aluminium et embouts en inox 403 - <i>Flangia in alluminio e boccole in AISI304</i>
D	Aluminium flange and Stainless steel (AISI316) bush - <i>Flansche aus Alu, Buchsen 1.4401</i> Brides en aluminium et embouts en inox 316 - <i>Flangia in alluminio e boccole in AISI316</i>
E	Flange and bush in aluminium (USA norm) - <i>Flansche gem. US-Norm, Buchsen aus Alu</i> Brides à normes USA et embouts en aluminium - <i>Flange (Norme USA)e boccole in alluminio</i>
F	Aluminium threaded bush - <i>Gewindebuchse aus Aluminium</i> Embout fileté en aluminium - <i>Boccola filettata in alluminio</i>
G	Plastic threaded bush - <i>Gewindebuchse aus Kunststoff</i> Embout fileté en plastique - <i>Boccola filettata in plastica</i>
H	Stainless steel (AISI 304) threaded bush - <i>Gewindebuchse aus Edelstahl 1.4301</i> Embout fileté en acier inox 304 - <i>Boccola filettata in AISI304</i>
I	Stainless steel (AISI 316) threaded bush - <i>Gewindebuchse aus Edelstahl 1.4401</i> Embout fileté en acier inox 316 - <i>Boccola filettata in AISI 316</i>
L	Hardened threaded bush - <i>Gewindebuchse gehärtet</i> Embout fileté durci - <i>Boccole filettate indurite</i>
M	Stainless steel (AISI 304) threaded bush (Thyssen) - <i>Gewindebuchse aus 1.4301 (Thyssen)</i> Embout fileté en inox 304 (Thyssen) - <i>Boccola filettata in AISI 304 (Thyssen)</i>

m m

013	13	065	65
020	20	080	80
025	25	100	100
032	32	125	125
040	40	150	150
050	50	200	200

VM

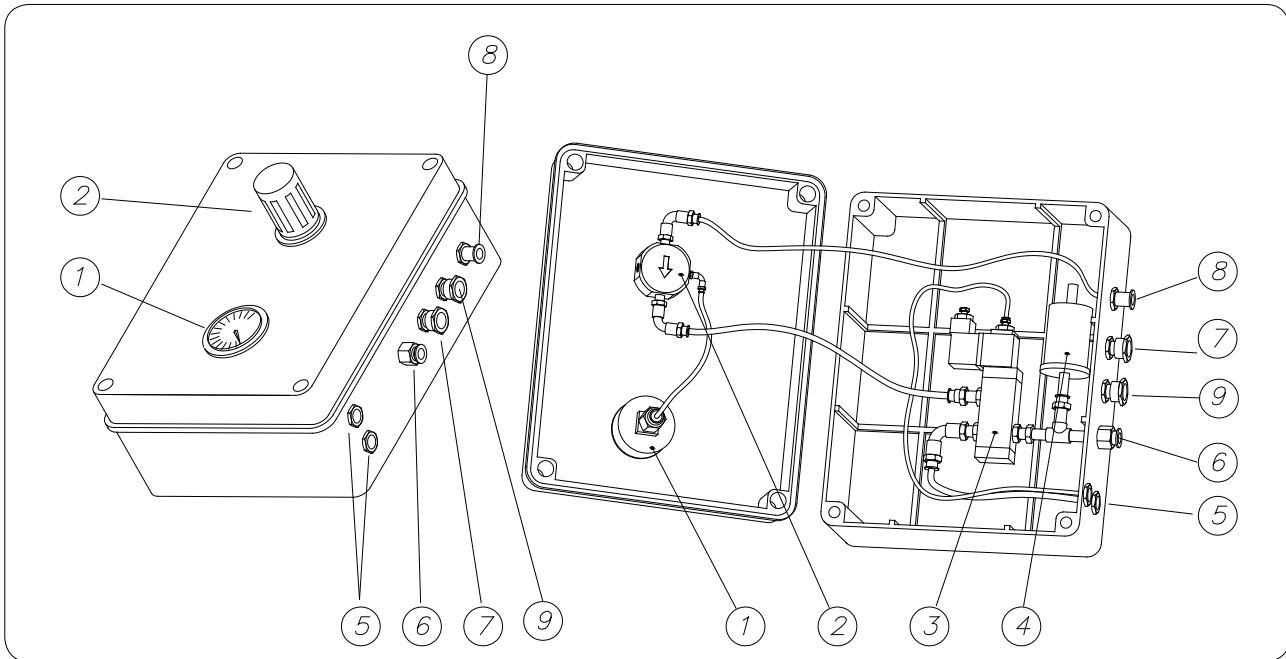

Item Pos.	Description - Beschreibung - Désignation - Descrizione
1	Pressure gauge - <i>Manometer</i> - Manomètre - <i>Manometro</i>
2	Pressure reducer - <i>Druckminderer</i> - Réducteur de pression - <i>Riduttore di pressione</i>
3	Solenoid valve - <i>Magnetventil</i> - Electrovanne - <i>Elettrovalvola</i>
4	Pressure switch - <i>Druckwächter</i> - Pressostat - <i>Pressostato</i>
5	Air outlets - <i>Luftauslässe</i> - Sorties d'air - <i>Scarichi aria</i>
6	Quick coupling 8 x 6 PV connection - <i>Schnellkupplung 8 x 6 Anschluss VM</i> Prise rapide 8 x 6 branchement VM- <i>Attacco rapido 8 x 6 collegamento VM</i>
7	Cable gland PG 9 pressure switch connection cable - <i>Kabelverschraubung PG 9 Anschlusskabel Druckwächter</i> Serre-câble PG 9 câble branchement pressostat - <i>Pressacavo PG 9 cavo collegamento pressostato</i>
8	Quick coupling 8 x 6 air inlet - <i>Schnellkupplung 8 x 6 Lufteinlass</i> Prise rapide 8 x 6 entrée aire - <i>Attacco rapido 8 x 6 ingresso aria</i>
9	Cable gland PG 9 solenoid valve connection cable - <i>Kabelverschraubung PG 9 Anschlusskabel Magnetventil</i> Serre-câble PG 9 câble branchement électrovanne - <i>Pressacavo PG 9 cavo collegamento elettrovalola</i>

**VMX - INSIDE VIEW - VMX - INNENANSICHT
VMX - ASPECT INTERIEUR - VMX - ASPETTO INTERNO**

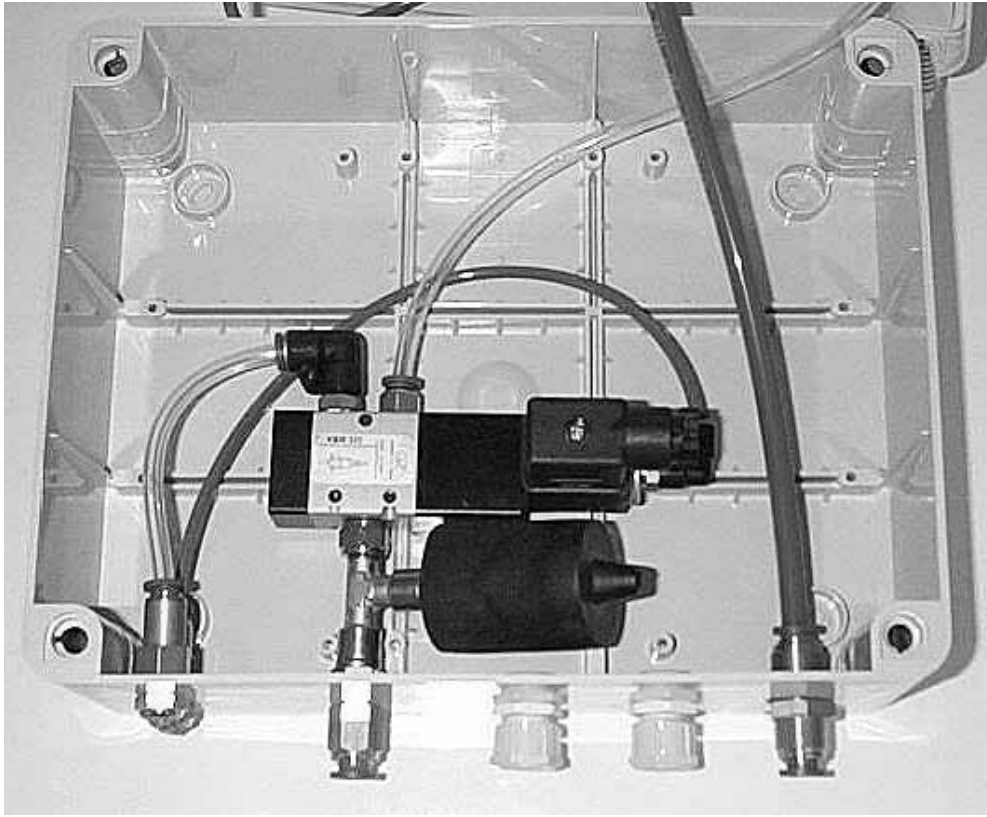

**VMX - OUTSIDE VIEW - VMX - AUSSENANSICHT
VMX - ASPECT EXTERIEUR - VMX - ASPETTO ESTERNO**

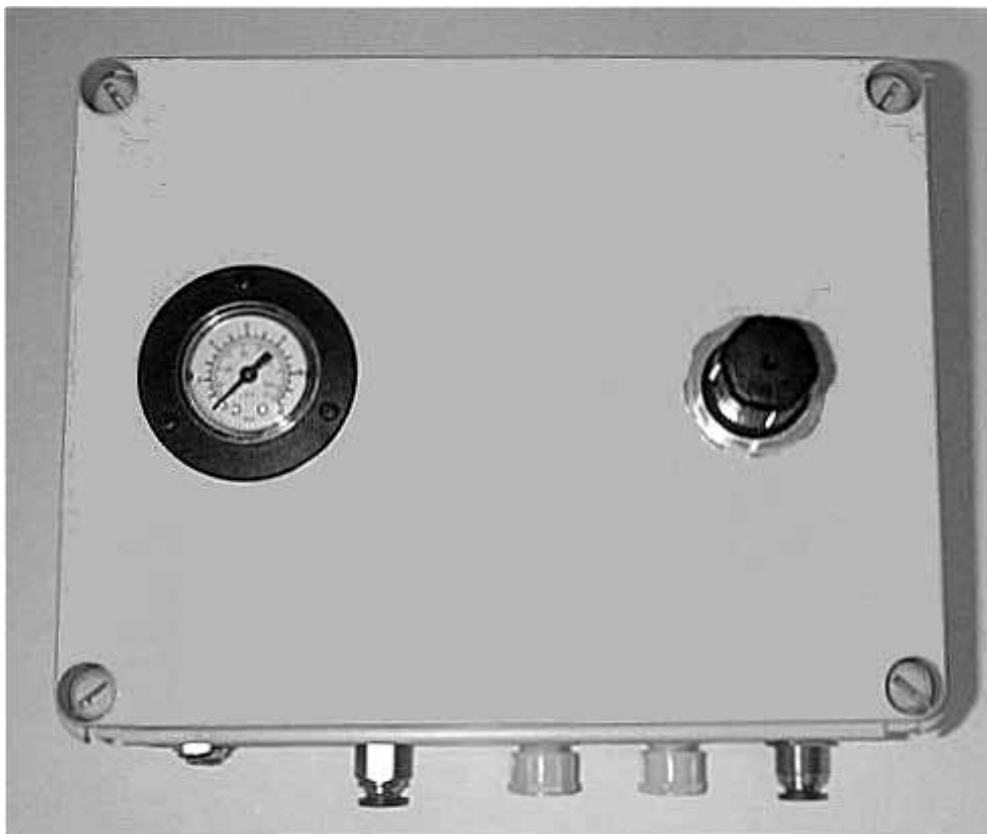

GENERAL TECHNICAL CARD - ALLGEMEINE TECHNISCHE KARTE - FICHE TECHNICIEN GÉNÉRALE - SCHEDA TECNICA GENERALE									
COMMANDO CRABPOT VALVE VMX01N - CONTROL VENTILHÜLSE VMX01 - COMMANDE SOUPE A MANCHON VMX01 - COMANDO VALVOLA A MANICOTTO VMX01									
SOLENOID - SOLENOID - SOLENOÏDE - ELETTRIVALVOLE									
TYPE TYPE TIP TIPO	EXERCISE TEMPERATURE TEMPERATUR DER ÜBUNG TEMPERATURE D'EXERCISE TEMPERATURA DI ESERCIZIO (°C)	FEEDING TENSION SPANUNGS-FÜTTERUNG ALIMENTATION DE TENSION TENSIONE ALIMENTAZIONE	ELECTRICAL CONNECTION CABLE ELEKTRISCHER ANSCHLUSS KABEL CÂBLE ÉLECTRIQUE DE RACCORDEMENT CAVO COLLEGAMENTO ELETTRICO	COMPRESSED AIR TUBE DRÜCKLUFT-SCHLAUCH TUBE D'AIR COMPRIÈME TUBO ARIA COMPRESSA (mm)	CONSUMPTION ENERGY VERBRAUCHS-ENERGIE CONSOMME DE L'ÉNERGIE CONSUMO ENERGIA (W)	PROTECTION SCHUTZ PROTECTION PROTEZIONE	EXERCISE PRESSURE ÜBUNGS-DRUCK PRESSION D'EXERCISE PRESSIONE DI ESERCIZIO (bar)		
COMMAND WITH ELECTROVALVE WITHOUT SOLENOID - BEFEHL MIT ELEKTROVENTIL OHNE SOLENOÏD - C-COMMANDE AVEC L'ÉLECTROVALVE SANS SOLENOÏDE - COMANDO CON ELETTRIVALVOLA SENZA SOLENOÏDE									
VMX01N									
SOLENOÏDE 6740010020	- 10 + 50	24 Volt, 50-60 Hz	3 x 1,5 mm ²	6 x 8	10	IP 55	3,5		
SOLENOÏDE 6740010040	- 10 + 50	24 Volt C.C., CC, GS, DC	3 x 1,5 mm ²	6 x 8	10	IP 55	3,5		
SOLENOÏDE 6740010060	- 10 + 50	110 Volt, 50-60 Hz	3 x 1,5 mm ²	6 x 8	10	IP 55	3,5		
SOLENOÏDE 6740010040	- 10 + 50	24 Volt C.C., Doppio Solenoide CC Double Solenide GS mit Doppelspule DC Double Solenoid	3 x 1,5 mm ²	6 x 8	10	IP 55	3,5		
SOLENOÏDE 6740010080	- 10 + 50	220 Volt, 50-60 Hz	3 x 1,5 mm ²	6 x 8	10	IP 55	3,5		
PRESSURE - DRUCK - PRESSION - PRESSOSTATO									
	EXERCISE TEMPERATURE TEMPERATUR DER ÜBUNG TEMPERATURE D'EXERCISE TEMPERATURA DI ESERCIZIO (°C)	CALIBRATION PRESSURE KALIBRIERUNGS-DRUCK PRESSION DE CALIBRAGE PRESSIONE TARATURA (bar)	ELECTRICAL CONNECTION CABLE ELEKTRISCHER ANSCHLUSS KABEL CÂBLE ÉLECTRIQUE DE RACCORDEMENT CAVO COLLEGAMENTO ELETTRICO	ELECTRICAL CONTACTS ELEKTRISCHE KONTAKTE CONTACTS ÉLECTRIQUES CONTATTI ELETTRICI	CONSUMPTION ENERGY VERBRAUCHS-ENERGIE CONSOMME DE L'ÉNERGIE CONSUMO ENERGIA (W)	PROTECTION SCHUTZ PROTECTION PROTEZIONE	EXERCISE PRESSURE ÜBUNGS-DRUCK PRESSION D'EXERCISE PRESSIONE DI ESERCIZIO (bar)		
	- 20 + 80	1,5	2 x 1,5 mm ²	220 Volt / 3 Amp.	0,5	IP 55	8 - 10		

DIMENSIONS OF VMX01 CONTROL PANEL - ABMESSUNGEN DER STEUERUNG VMX01
DIMENSIONS TABLEAU DE COMMANDE VMX01 - DIMENSIONI QUADRO DI COMANDO VMX01

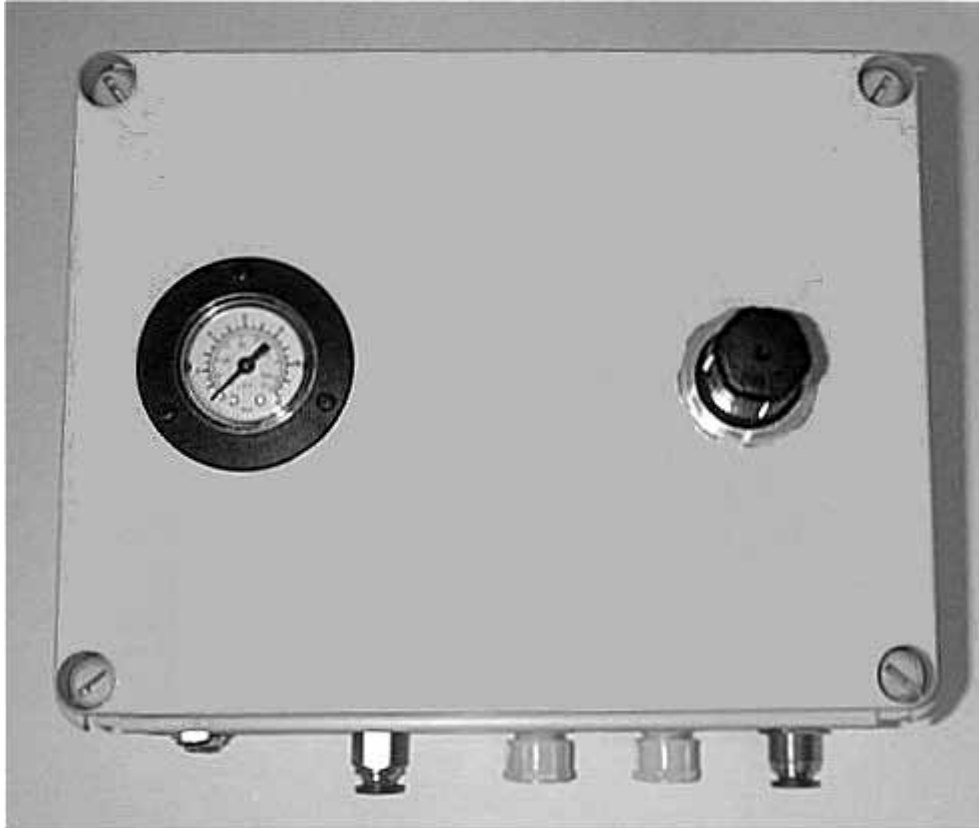

Box - Gehäuse Boîte - Scatola	GEWISS 250x200x100
Protection - Schutz Protection - Protezione	IP 55
Weight - Gewicht Poid - Peso	1.9 kg

PINCH VALVE - QUETSCHVENTIL - VANNE A MANCHON - VALVOLA A MANICOTTO

VALVE DIAMETER - VENTILDURCHMESSER 13 20 25 32 40 50 65 80 100 125 150 200
 DIAMETRE VANNE - DIAMETRO VALVOLA

**INLET SPOUT
EINLAUF
BOUCHE D'ENTRÉE
BOCCA DI ENTRATA**

- | | |
|--|---|
| Aluminium bush - Aluminiumbuchse <input type="checkbox"/>
Bague en Aluminium - <i>Boccola Alluminio</i> <input type="checkbox"/>
AISI 304 bush - <i>Buchse Edelstahl 1.4301</i> <input type="checkbox"/>
Bague en AISI 304 - <i>Boccola AISI 304</i> <input type="checkbox"/>
AISI 316 bush - <i>Buchse Edelstahl 1.4401</i> <input type="checkbox"/>
Bague en AISI 316 - <i>Boccola AISI 316</i> <input type="checkbox"/>
Hardened bush - <i>Buchse, gehärtet</i> <input type="checkbox"/>
Manchon trempé - <i>Boccola indurita</i> <input type="checkbox"/>
Aluminium flange - <i>Aluminiumflansch</i> <input type="checkbox"/>
Bride Aluminium - <i>Flangia Alluminio</i> <input type="checkbox"/>
Aluminium flange USA standards - <i>Aluminiumflansch USA-Norm</i> <input type="checkbox"/>
Bride Aluminium normes USA - <i>Flangia Alluminio norme USA</i> <input type="checkbox"/> | Threaded aluminium bush - <i>Aluminiumbuchse mit Gewinde</i> <input type="checkbox"/>
Bague Filetée en Aluminium - <i>Boccola Alluminio Filettata</i> <input type="checkbox"/>
Threaded AISI 304 bush - <i>Gewindebuchse Edelstahl 1.4301</i> <input type="checkbox"/>
Bague Filetée en AISI 304 - <i>Boccola AISI 304 Filettata</i> <input type="checkbox"/>
Threaded AISI 316 bush - <i>Gewindebuchse Edelstahl 1.4401</i> <input type="checkbox"/>
Bague Filetée en AISI 316 - <i>Boccola AISI 316 Filettata</i> <input type="checkbox"/>
Threaded hardened bush - <i>Gewindebuchse, gehärtet</i> <input type="checkbox"/>
Manchon Fileté trempé - <i>Boccola indurita Filettata</i> <input type="checkbox"/> |
|--|---|

**OUTLET SPOUT
AUSLAUF
BOUCHE DE SORTIE
BOCCA DI USCITA**

- | | |
|--|---|
| Aluminium bush - Aluminiumbuchse <input type="checkbox"/>
Bague en Aluminium - <i>Boccola Alluminio</i> <input type="checkbox"/>
AISI 304 bush - <i>Buchse Edelstahl 1.4301</i> <input type="checkbox"/>
Bague en AISI 304 - <i>Boccola AISI 304</i> <input type="checkbox"/>
AISI 316 bush - <i>Buchse Edelstahl 1.4401</i> <input type="checkbox"/>
Bague en AISI 316 - <i>Boccola AISI 316</i> <input type="checkbox"/>
Hardened bush - <i>Buchse, gehärtet</i> <input type="checkbox"/>
Manchon trempé - <i>Boccola indurita</i> <input type="checkbox"/>
Aluminium flange - <i>Aluminiumflansch</i> <input type="checkbox"/>
Bride Aluminium - <i>Flangia Alluminio</i> <input type="checkbox"/>
Aluminium flange USA standards - <i>Aluminiumflansch USA-Norm</i> <input type="checkbox"/>
Bride Aluminium normes USA - <i>Flangia Alluminio norme USA</i> <input type="checkbox"/> | Threaded aluminium bush - <i>Aluminiumbuchse mit Gewinde</i> <input type="checkbox"/>
Bague Filetée en Aluminium - <i>Boccola Alluminio Filettata</i> <input type="checkbox"/>
Threaded AISI 304 bush - <i>Gewindebuchse Edelstahl 1.4301</i> <input type="checkbox"/>
Bague Filetée en AISI 304 - <i>Boccola AISI 304 Filettata</i> <input type="checkbox"/>
Threaded AISI 316 bush - <i>Gewindebuchse Edelstahl 1.4401</i> <input type="checkbox"/>
Bague Filetée en AISI 316 - <i>Boccola AISI 316 Filettata</i> <input type="checkbox"/>
Threaded hardened bush - <i>Gewindebuchse, gehärtet</i> <input type="checkbox"/>
Manchon Fileté trempé - <i>Boccola indurita Filettata</i> <input type="checkbox"/> |
|--|---|

SLEEVE - MANCHETTE - MANCHON - MANICOTTO:

- | | |
|--|--|
| Natural rubber - <i>Naturgummi</i> <input type="checkbox"/>
Caoutchouc naturel - <i>Gomma naturale</i> <input type="checkbox"/> | Food-grade NBR - <i>NBR lebensmittelecht</i> <input type="checkbox"/>
NBR de qualité al. - <i>NBR alimentare</i> <input type="checkbox"/> |
|--|--|

Application - Anwendung - Application - Applicazione

- | | | |
|---|--|--|
| Pneumatic transport - <i>Pneumatische Beförderung</i> <input type="checkbox"/>
Transport pneumatique - <i>Trasporto pneumatico</i> | Safety system - Loading silos <input type="checkbox"/>
<i>Sicherheitssystem - Silobeschickung</i>
Système de sécurité - <i>Chargement silo</i>
Sistema di sicurezza - <i>Caricamento silo</i> | Other - <i>Anderes</i>
Autre - <i>Altro</i>
.....
..... |
| Pneumatic conveying pressure.....bar
<i>Pneumatischer Beförderungsdruck</i>bar
Pression transport pneumatique.....bar
<i>Pressione trasporto pneumatico</i>bar | Ambient temperature.....°C
<i>Umgebungstemperatur</i>°C
Température Ambiante.....°C
<i>Temperatura Ambiente</i>°C | |

- | | | |
|--|---|---|
| Operating conditions - <i>Im Ruhezustand geöffnet</i> :
Conditions d'Utilisation - <i>Condizioni Utilizzo</i> : | Normally open - <i>Normalmente aperta</i> <input type="checkbox"/>
<i>Im Ruhezustand geöffnet - Normalmente aperta</i> | Normally closed - <i>Im Ruhezustand geschlossen</i> <input type="checkbox"/>
<i>Normalment fermée - Normalmente chiusa</i> |
|--|---|---|

Materials - Materialen - Matériaux - Materiali

Type of material - *Materialtyp* - Type du matériau - *Tipo materiale*.....
 Density - *Schüttgewicht* - Densité - *Densità*.....kg /m³
 Granulometrie - *Körnung* - Granulometrie - *Granulometria*.....
 Temperature - *Temperatur* - Temperature - *Temperatura*.....°C

- | | | | |
|---|---|--|--|
| Flowable - <i>Rieselfähig</i> Yes - Ja <input type="checkbox"/> No - Nein <input type="checkbox"/>
Fluide - <i>Scorrevole</i> Oui - Si <input type="checkbox"/> No - No <input type="checkbox"/> | Abrasive - <i>Abrasiv</i> Yes - Ja <input type="checkbox"/> No - Nein <input type="checkbox"/>
Abrasif - <i>Abrasivo</i> Oui - Si <input type="checkbox"/> No - No <input type="checkbox"/> | Compacting - <i>Packend</i> Yes - Ja <input type="checkbox"/> No - Nein <input type="checkbox"/>
Colmatant - <i>Impaccante</i> Oui - Si <input type="checkbox"/> No - No <input type="checkbox"/> | |
| Hygroscopic - <i>IHygrosc.</i> Yes - Ja <input type="checkbox"/> No - Nein <input type="checkbox"/>
Hygroscopique - <i>Igrosc.</i> Oui - Si <input type="checkbox"/> No - No <input type="checkbox"/> | Dusty - <i>Pulverförmig</i> Yes - Ja <input type="checkbox"/> No - Nein <input type="checkbox"/>
Poussiéreux - <i>Polveroso</i> Oui - Si <input type="checkbox"/> No - No <input type="checkbox"/> | Viscous - <i>Viskös</i> Yes - Ja <input type="checkbox"/> No - Nein <input type="checkbox"/>
Viscqueux - <i>Viscoso</i> Oui - Si <input type="checkbox"/> No - No <input type="checkbox"/> | |
| Inflammable - <i>Feuergefährlich</i> Yes - Ja <input type="checkbox"/> No - Nein <input type="checkbox"/>
Inflammable - <i>Inflammabile</i> Oui - Si <input type="checkbox"/> No - No <input type="checkbox"/> | Explosive - <i>Explosiv</i> Yes - Ja <input type="checkbox"/> No - Nein <input type="checkbox"/>
Explosif - <i>Esplosivo</i> Oui - Si <input type="checkbox"/> No - No <input type="checkbox"/> | Corrosive - <i>Korrosiv</i> Yes - Ja <input type="checkbox"/> No - Nein <input type="checkbox"/>
Corrosif - <i>Corrosivo</i> Oui - Si <input type="checkbox"/> No - No <input type="checkbox"/> | |
| Degradable - <i>Verderblich</i> Yes - Ja <input type="checkbox"/> No - Nein <input type="checkbox"/>
Degradable - <i>Degradabile</i> Oui - Si <input type="checkbox"/> No - No <input type="checkbox"/> | Acid - <i>Säure</i> Yes - Ja <input type="checkbox"/> No - Nein <input type="checkbox"/>
Acide - <i>Acido</i> Oui - Si <input type="checkbox"/> No - No <input type="checkbox"/> | Basic - <i>Lauge</i> Yes - Ja <input type="checkbox"/> No - Nein <input type="checkbox"/>
Basique - <i>Basico</i> Oui - Si <input type="checkbox"/> No - No <input type="checkbox"/> | |
| Adhesive - <i>Kleband</i> Yes - Ja <input type="checkbox"/> No - Nein <input type="checkbox"/>
Adhésif - <i>Adesivo</i> Oui - Si <input type="checkbox"/> No - No <input type="checkbox"/> | Generates electrostatic charges - <i>Erzeugt elektrostatische Entladungen</i>
Produit des charges électrostatiques - <i>Genera carica elettrostatiche</i> | Yes - Ja <input type="checkbox"/> No - Nein <input type="checkbox"/>
Oui - Si <input type="checkbox"/> No - No <input type="checkbox"/> | |

N.B. Rights reserved to modify technical specifications

N.B. Angaben ohne Gewähr. Änderungen können ohne Vorankündigung vorgenommen werden.

N.B. Toutes données portées dans le présent catalogue n'engagent pas le fabricant. Elles peuvent être modifiées à tout moment.

N.B. Tutti i dati riportati nel presente catalogo non sono impegnativi e possono subire variazioni in qualsiasi momento.



TOREX®

TOREX S.p.A.
Via Canaletto, 139/A
I - 41030 San Prospero
(MO) - ITALY

 + 39 / 059 / 8080811
fax + 39 / 059 / 908204
e-mail torex@torex.it
internet www.torex.it